

KD457.45

Disassembly/ Assembly recommendations

AUDI:	A4 (Series 1 FL, Series 2, Series 2 FL, Cabriolet I and II), A6 (Series 2 and 2 FL)	ENGINES 1.8 i, 1.8 i Turbo, 2.0 i, 2.0 i Turbo	OE reference 06B198119A, 06B198119C
SKODA:	Superb		
VOLKSWAGEN:	Passat V FL		
SEAT:	Exeo		

IDENTIFICATION OF TIMING KIT KD457.45

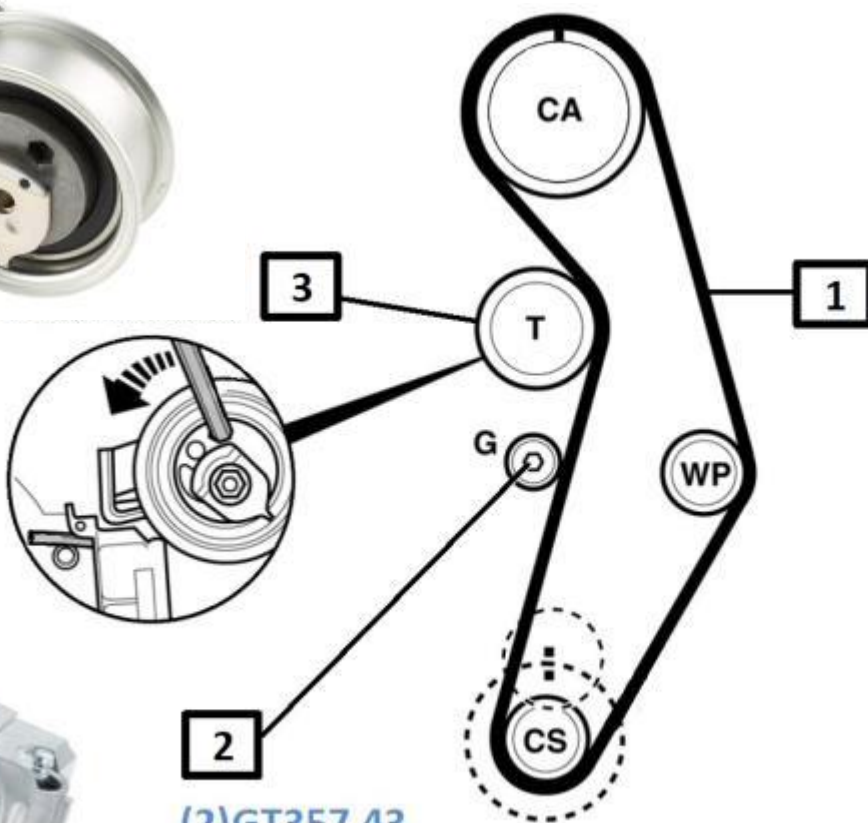

**(1) TOOTHED
BELT**
150 teeth
OE: 06B109119A

(2) GT357.43
OE: 06B109477A



COMMON PROBLEMS

INCORRECT INSTALLATION

Probable cause

Incorrect arrangement of the tensioner

- When using a hydraulic tensioner, care must be taken during the installation process to ensure correct fitment.
- It is recommended not to remove the locking pin from the tensioner until it has been fitted securely in place.

PROBLEMS OF INCORRECT BELT TENSION

Probable cause

Incorrect installation of the roller

- The hydraulic tensioner requires a particular installation procedure. Failure to follow this procedure will result in incorrect timing belt tension and leave a heavy or offset mark on the tensioner shaft.
- Incorrect fitment of the hydraulic tensioner can also cause the base of the tensioner to break.



Offset contact zone

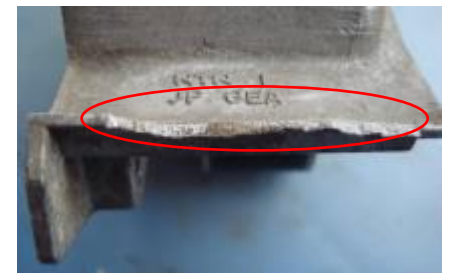

Broken tensioner

Consequences

Engine damage

These types of malfunctions generally cause significant engine damage.

**Reminder:**

- **Never compress the hydraulic cylinder while it is horizontal.**
- **Do not remove the tensioner locking pin before completing the installation of the roller and the timing belt.**



RECOMMENDATIONS

- Kit KD457.45 must be installed in accordance with the manufacturer's installation procedures, failure to do so may result in severe engine damage.
- Kit KD457.45 requires specialist fitment tools to correctly install the kit to the manufactures specifications.

REPLACEMENT

Special tools:

- Tensioner roller timing pin
- Double hook wrench

SNR recommends using HAZET tool
4794/35

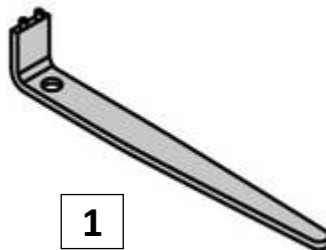
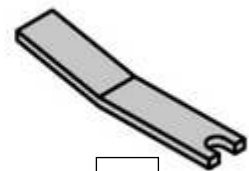
**1****2****Precautions:**

- Disconnect the earth lead from the battery
- **DO NOT** rotate the crankshaft or the camshafts while the timing belt has been removed
- Remove the spark plugs to make engine rotation easier
- Rotate the engine in the normal direction of rotation (unless indicated otherwise)
- **DO NOT** rotate the engine with the camshafts or other drive pinions
- Follow all tightening torque specifications

Removal of GT357.43

1) Rotate the crankshaft clockwise to top dead centre (TDC)

2) Remove the crankshaft pulley

3) Use an Allen key to rotate tensioner roller GT357.48 slowly anti-clockwise (no.1)

4) Block the hydraulic tensioner (no.3) with a pin (no.2)

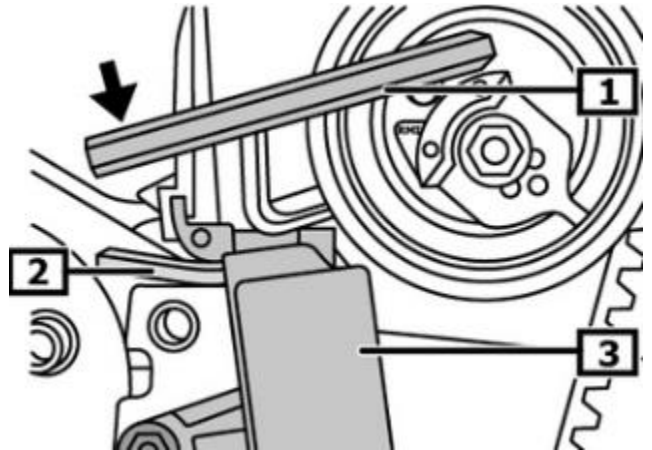

5) Loosen the nut of tensioner roller GT357.48 and then turn it slowly clockwise

6) Remove the timing belt and hydraulic tensioner GT357.48

Re-installation of GT357.43

1) Check to ensure that the timing marks of the camshaft gear are aligned and that the roller fits correctly

See TechInfo “Hydraulic tensioners”

If the locking pin has been removed too soon it is possible to reset the tensioner as follows.

Use a press to slowly compress the piston (**no. 1**) into the body of the tensioner (**no.3**) until the holes on the tensioner body and piston line up. This must be carried out with the cylinder in the vertical position.



Do not exceed a force of 1000 Nm when compressing the piston

2) Re-install the hydraulic tensioner and the tensioner roller

3) Re-install the crankshaft pulley and the belt

4) Use the double hook wrench to rotate the tensioner roller slowly anti-clockwise (no.5)

until the tensioner roller locking pin (Rep.6) can be removed

5) Rotate the tensioner roller clockwise

dimension $x = 8 \text{ mm}$

6) Tighten the tensioner roller nut

7) Make sure that marks (3 and 4) are properly aligned that dimension x remains between 6 and 10 mm while turning the crankshaft through two full rotations

8) Re-install the remaining components in the reverse of the order in which you removed them.

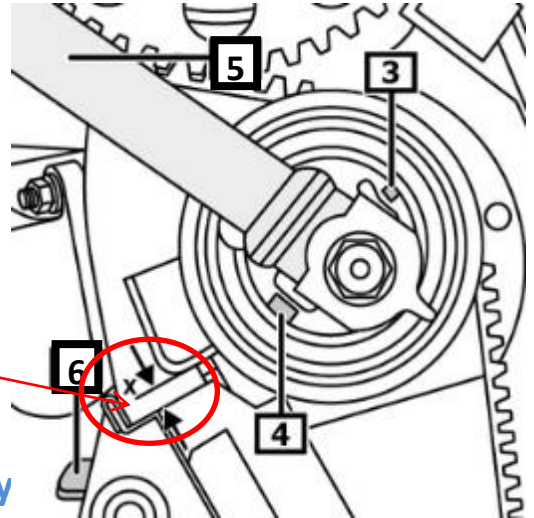

Recommendations

Follow the hydraulic cylinder tensioning procedure in order to prevent excessive play between the cylinder shaft and the support on the engine block.

Follow the vehicle manufacturer's installation procedures and apply the specified tightening torques.

Refer to the vehicle applications in our online catalogue: <http://lc.cx/catalog-ra>



Scan this QR code to access our online catalogue.

FOLLOW THE RECOMMENDATIONS OF THE VEHICLE MANUFACTURER!

©NTN-SNR ROULEMENTS

The contents of this document are the copyright of the publisher and any reproduction, even partial, is prohibited without permission.

Despite the care taken in preparing this document, NTN-SNR Roulements disclaims any liability for errors or omissions that may slip through, as well as for losses or direct or indirect damage arising from its use.

www.nten-snr.com

NTN. SNR.