



Technical Report #58

Valve stem seals choice in B41 to B62 Volvo engines

Technical Report

Purpose

To indicate the main differences between valve stem seals in B41 to B62 Volvo engines.

Description

B41 to B62 engines family from the Swedish manufacturer uses two types of valve that differ, among other features, in the stem diameter. In consequence, AJUSA has two different valve stem seal part numbers for these engines.

These valve stem seals are mounted in models such as S40, V40, S60, S70, S80, V70, XC70 and C70 manufactured from 1998.

The type of valve stem seals mounted in each vehicle depends on the engine manufacturing number, which can be found in a label on the timing cover, or engraved in the block near the flywheel.

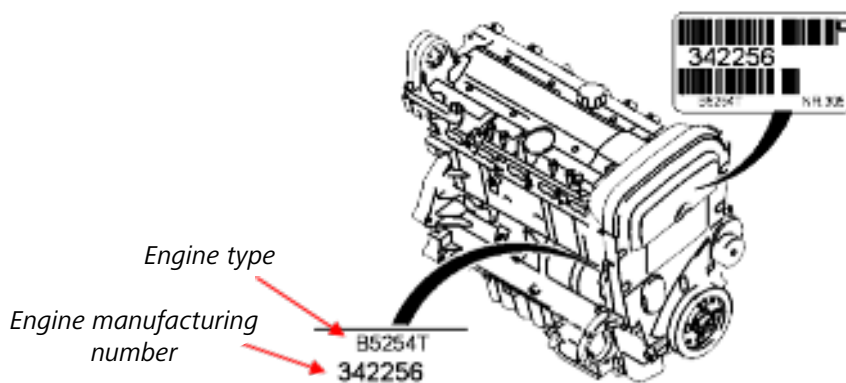

ENGINE CODE	MODEL	ENGINE MANUFACTURE NUMBER: VALVE STEM SEAL
B4164S	V40/S40	< 1818168 :12005300 1818169 > :12021000
B4184S		
B4194T		
B4204S-T		
B6284T	S80	< 1817652: 12005300 1817653 >: 12021000
B6304S		
B6294S-T		
B5204T4-5	S80/S60/C70/V70	< 1817652: 12005300 1817653 >: 12021000
B5234T	S60/S70/S70/S80	
B5244S-T	X60/X80/C70	
B5254T	S80	

If this number cannot be found, the valve stem seals can also be chosen by measuring the valve stem diameter, which will determine the inner diameter of the seal lip.

The part numbers of the valve stem seals depending on the engine manufacturing number and valve stem diameter are the following:



ENGINE MANUFACTURE N°	VALVE STEM DIAMETER	VALVE STEM SEAL
< 1818168	7 mm	12005300
< 1817652		
1818169 >	6 mm	12021000
1817653 >		