



BMW 5er E60 / E61

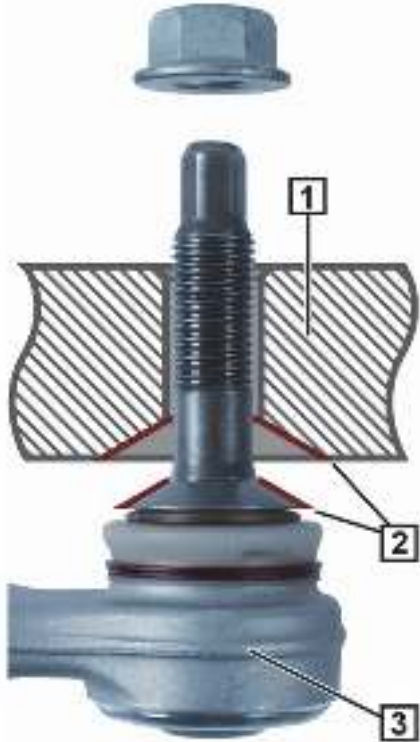

Fig.1: Rear axle control with cone seat (2)

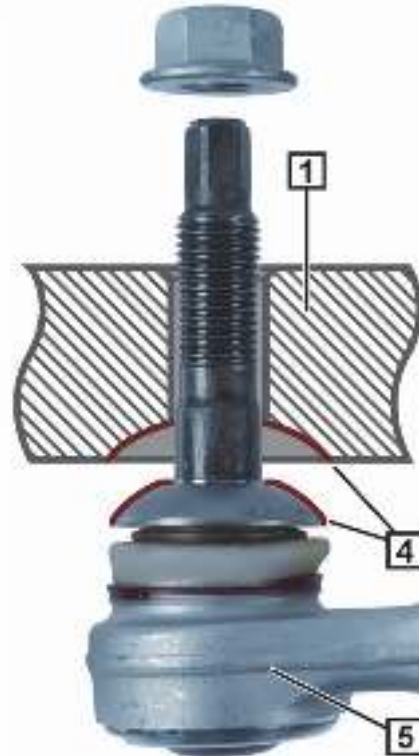

Fig.2: Rear axle control arm with ball seat (4)



Wheel carrier (1) and control arm (3 / 5) for the rear axle were changed from cone seat (2) to ball seat (4).

Prior to installation, check whether the control arm model is compatible with the wheel carrier.

Year of construction	Model	Part no. LEMFÖRDER	Part no. BMW
→ 02 / 2005	Cone seat (2)	34465 01	33 32 6 777 425
→ 02 / 2005	Cone seat (2)	34466 01	33 32 6 777 426
02 / 2005 →	Cone seat (4)	27192 02	33 30 6 772 241
02 / 2005 →	Cone seat (4)	27193 02	33 30 6 772 242



www.zf.com/serviceinformation