

# NT 13001

VKD 13500 – VKD 13501

VKDS 13500 – VKDS 13501

PSA

VKD 13500



VKD 13501



VKDS 13500



VKDS 13501



- (4) Hub locking tool (No. 0606-AY).
- (15) Ball joint removal/refitting tool (Facom SP.150707).
  - Grease (Total N4128).
  - Lower suspension joint mounting tool (SKF TMFT 33-B 30/55).
  - Loctite product 7800.

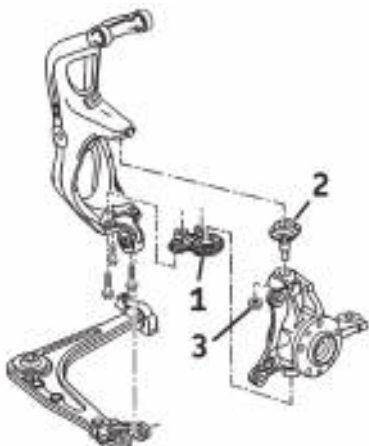

- Transmission shaft fixing nut: 345 Nm
- Wheel sensor fixing: 10 Nm
- Flexible brake hose support fixing screws (5): 40 Nm
- Steering rod nut (8): 35 Nm
- Brake calliper fixing nut: 30 Nm
- Brake disc fixing screws: 10 Nm
- Stabilizer link rod nut (9): 85 Nm
- Screws (10) securing the stabilizer link rod to the shock absorber support: 205 Nm
- Screws (11) securing the suspension wishbone to the shock absorber support: 75 Nm.

A

B

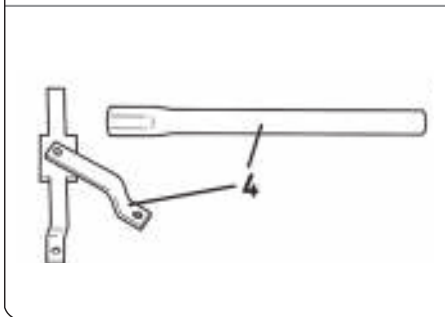

C

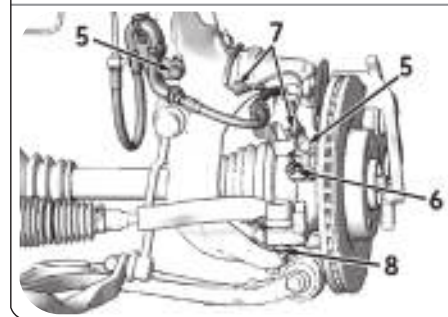

D

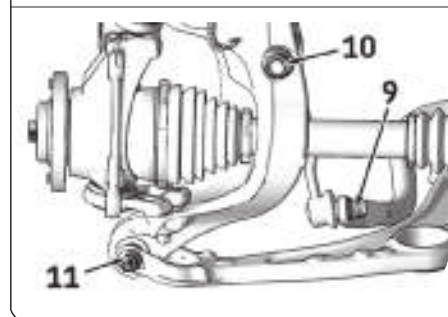

## Removing the front knuckle

**Caution:** The front knuckle must be removed to facilitate the mounting of the ball joint and lower suspension joint.

- 1) Place the vehicle on an elevator platform.
  - 2) Loosen the bolts securing the wheel.
  - 3) Raise and support the vehicle in a safe manner with the front wheels clear of the platform.
  - 4) Remove the wheel, the pin and the cover of the metal nut securing the transmission shaft.
  - 5) (Fig. B): Immobilise the rotating hub using the tool (4).
  - 6) Remove the nut securing the transmission shaft to the hub.
  - 7) (Fig. C): Loosen the screws (5) securing the flexible brake hose.
  - 8) (Fig. C): Remove the wheel sensor (6).
  - 9) (Fig. C): Free and remove the wheel sensor wire (7).
  - 10) (Fig. C): Loosen then remove the track rod end nut (8). Then free the front pivot track rod end.
  - 11) Loosen then remove the brake caliper securing nuts. Disconnect and suspend the caliper.
  - 12) Loosen then remove the brake disc retaining nuts. Remove the brake disc.
  - 13) (Fig. D): Loosen then remove the stabilizer link rod nut (9). Remove the lower part of the stabilizer link.
  - 14) (Fig. D): Loosen then remove the holding screw (10) holding the shock absorber and the stabilizer link rod.
- Note:** (Fig. D): The holding screw (10) must be removed to avoid bending the shock absorber rod.
- 15) (Fig. D): Loosen then remove the suspension wishbone attachment (11).
  - 16) (Fig. E): Pull the shock absorber/knuckle assembly towards you while holding the transmission to pull it clear of the suspension wishbone. Loosen then remove the retaining screws (12) and (13) holding the lower suspension joint (1).
  - 17) (Fig. F): Loosen then remove the retaining nut (3) holding the ball joint (2).

**Note:** (Fig. F): When removing the retaining nut (3) make sure you do not damage the cv joint boot (14).

- 18) Keep the transmission shaft supported.
- 19) Remove the front knuckle. Removing and refitting the ball joint
- 20) (Fig. G): Place the tool (15) on the used ball joint (2). Loosen then remove the joint. Refitting the ball joint
- 21) (Fig. G): Mount the new ball joint (2) by hand on the shock absorber support then tighten it using the tool (15) to a torque of 150 Nm. Removing and refitting the lower suspension joint

### Important:

- Never pivot the joint through a large angle; use only small movements during assembly/disassembly, otherwise the internal assembly may be disturbed.
- Any parts that have been subject to impact or have fallen on the ground must not be fitted.
- On the new joint, check that the bearing inner ring is fully pushed into the housing.
- The joint must be protected during handling against any cuts or tears.
- (Fig. J): The ribs (16) must be protected from impact and deformation.
- Do not re-use a dismantled suspension joint.

**Install Confidence**



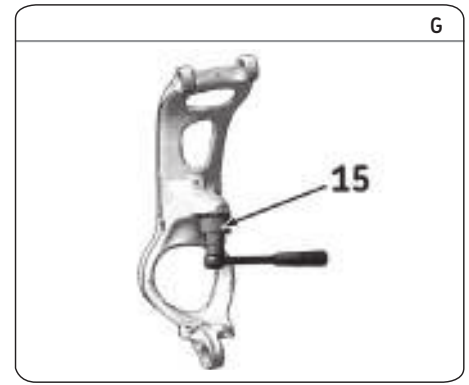
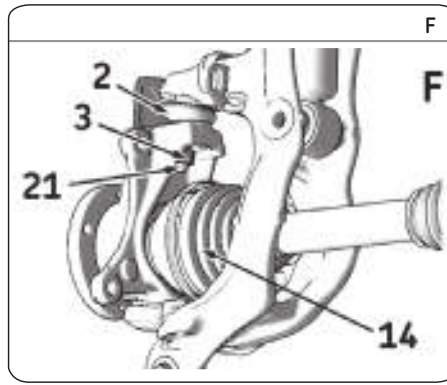
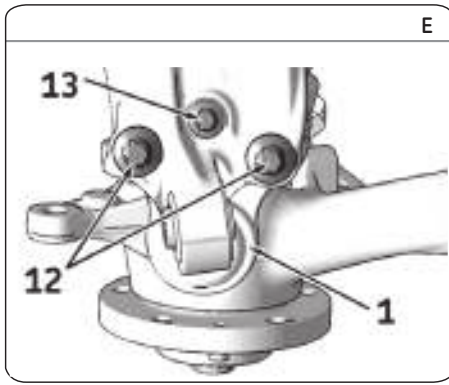

#### Removing the lower suspension joint

- 22) (Fig. H): Unclip the seal (17) using a fine screwdriver.  
 23) (Fig. H): Twisting the body (18) of the joint using a suitable tool (example: a screwdriver), separate the joint and the rollers from the front knuckle.

**Note:** (Fig. I): the internal ring (19) for the joint and the seal (17) remain fitted on the axis of the front knuckle.

- 24) Remove the internal ring (19) for the joint and the seal (17) using a hub extractor (or other similar tool). Refitting the lower suspension joint (on the front knuckle)

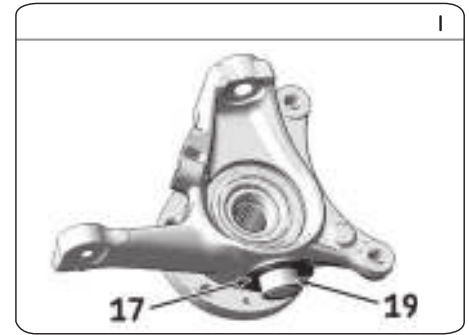
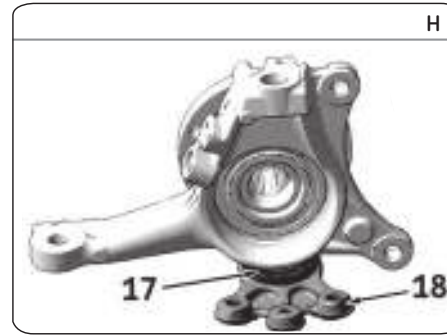

**Important note:** The condition of the seal contact surface on the front knuckle is critical to the durability of the replacement parts. The following instructions must be followed exactly. If the ball joint support surface located on the front knuckle (see the hatched area Fig. J) is severely damaged, replace the front knuckle and proceed from step 25). If not, proceed according to the following instructions.

**Caution:** The following operations must be carried out before fitting the lower suspension ball joint:

- Clean, then remove the grease from the ball joint support surface located on the front knuckle to remove all traces of corrosion. Allow the support surface to dry.
  - Protect the stub shaft of the front knuckle with rubber tape.
  - Evenly spray Loctite 7800 on the seal contact surface of the front knuckle (NB. the Loctite must not be applied on the whole knuckle).
  - Allow the Loctite 7800 to dry for 10 to 15 minutes
  - Repeat the application of the Loctite 7800 three more times, allowing 10–15 minutes drying time between each application (four layers of Loctite 7800 are therefore applied in total).
  - Remove the rubber tape from the stub shaft of the front knuckle.
- 25) (Fig. H): Apply a line of grease to the ball joint's seal lip (17) (Total N4128 grease).  
 26) (Fig. J): To ensure correct centring, pre-engage the joint bearing (1) onto the front knuckle stub shaft (20).  
 27) Mount the joint fully onto the front knuckle stub shaft by using a suitable tool, for example a ring or spacer of correct shape and diameter to fit the application area (see the greyed out area with the black arrows in Fig. J). Apply the mounting force in a uniform manner, in line with the stub shaft, using an appropriate device (example: a press, or SKF lower suspension joint mounting tool).

**Caution:** Check that the joint is correctly fitted. The stub shaft of the front knuckle must be pressed in until it is in

contact with the bottom of the joint housing. The lower suspension joint is then almost blocked from rotation (do not release the joint). Refitting the front knuckle

**Note:** Replace the original Nyloc nuts (self-threaded nuts) with new nuts.

- 28) Place the front knuckle on the shock absorber support:  
 - (Fig. F): the threaded rod (21) of the ball joint (2) is inserted into the hold on the upper part of the front knuckle.  
 - (Fig. K): the tapped holes of the lower suspension joint are centred on the holes (22) of the lower part of the shock absorber support.

**Caution:** Ensure that the ribs (16) (Fig. J) are placed in the marks (23) (Fig. K) left by the used suspension's lower joint.

- 29) (Fig. F): Tighten the nut (3) holding the ball joint using a torque of 60 Nm.

**Note:** The retaining screws (12) and (13) (Fig. E) of the lower suspension joint must be coated in thread lock paste before being tightened.

**Caution:** The retaining screws (12) must be tightened simultaneously in order to gradually release the lower suspension joint.

- 30) (Fig. E): Tighten the retaining screws (12) to 170 Nm.  
 31) (Fig. E): Tighten the retaining screws (13) to 65 Nm.  
 32) (Fig. E and Fig. F): The tightening of the retaining nut (3) and screws (12) and (13) must release the lower suspension joint. Check that it moves correctly (This operation also enables the grease applied to the seal lip (17) to be evenly distributed (Fig. H)).  
 33) Refit the remaining elements in the reverse sequence of removal.

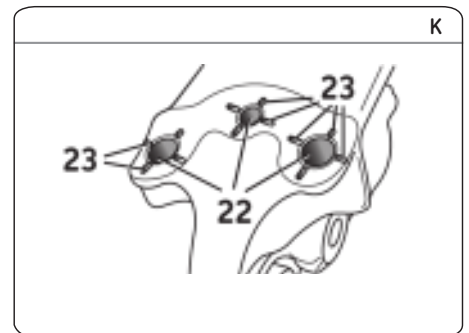
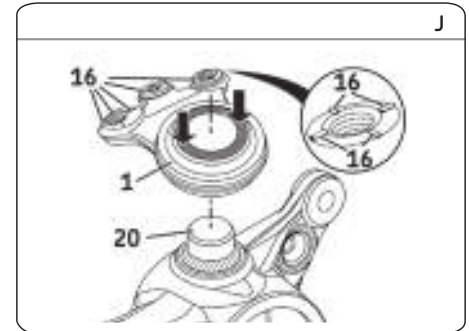

**Notice:** Always follow the vehicle manufacturer instructions when working on the engine. The SKF KITS are designed for the automotive repair professional and must be fitted using tooling used by these professionals. These instructions are to be used as a guideline only. This document is the exclusive property of SKF. Any representation, partial or full reproduction, is forbidden without prior written consent from SKF.